

SEA EAGLE

Leong Cheng Chit ©2001

Complex

(Singapore)

The model captures the moment of the eagle as it closes in on its prey.

A 24 inch square gives a 15 inch wing-span model. Use relatively stiff 110g paper for best effect.

Note: Many of the folds do not flatten completely. Do not force as this could tear the paper.

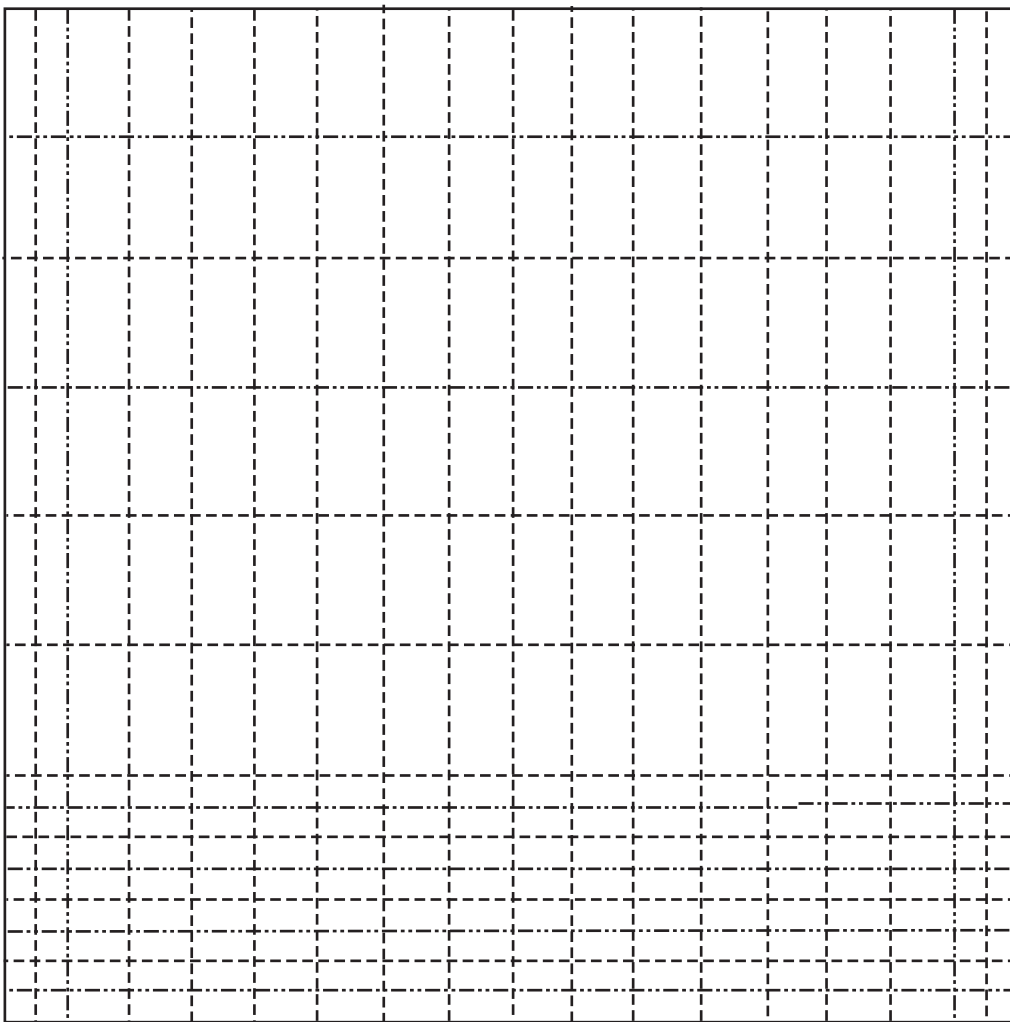

1. Crease (fold and unfold) paper along the valley and mountain fold lines. Fold first into $1/2$, then $1/4$, then $1/8$, then $1/16$ and finally $1/32$. Follow the valley and mountain folding pattern.

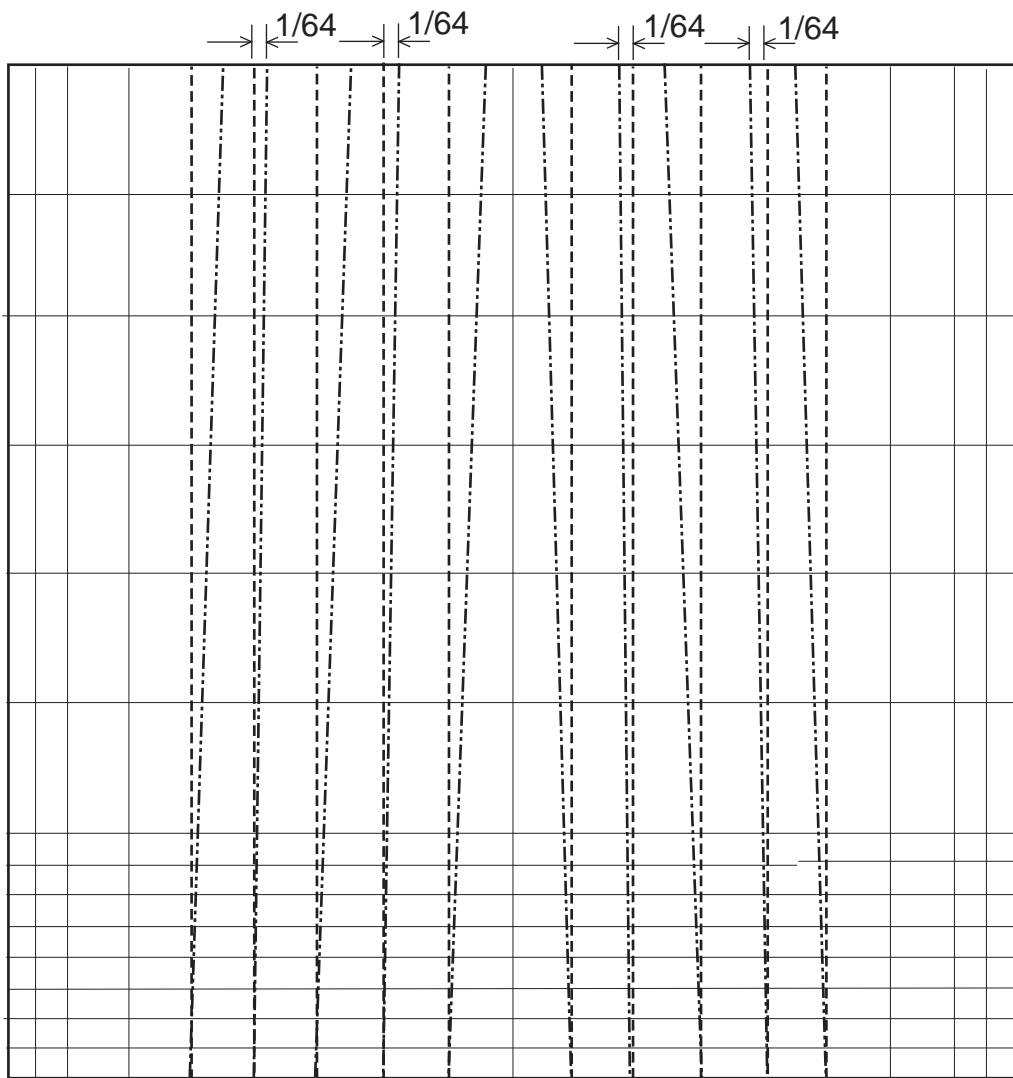

2. Pleat fold. These are non-parallel pleats or V-pleats.

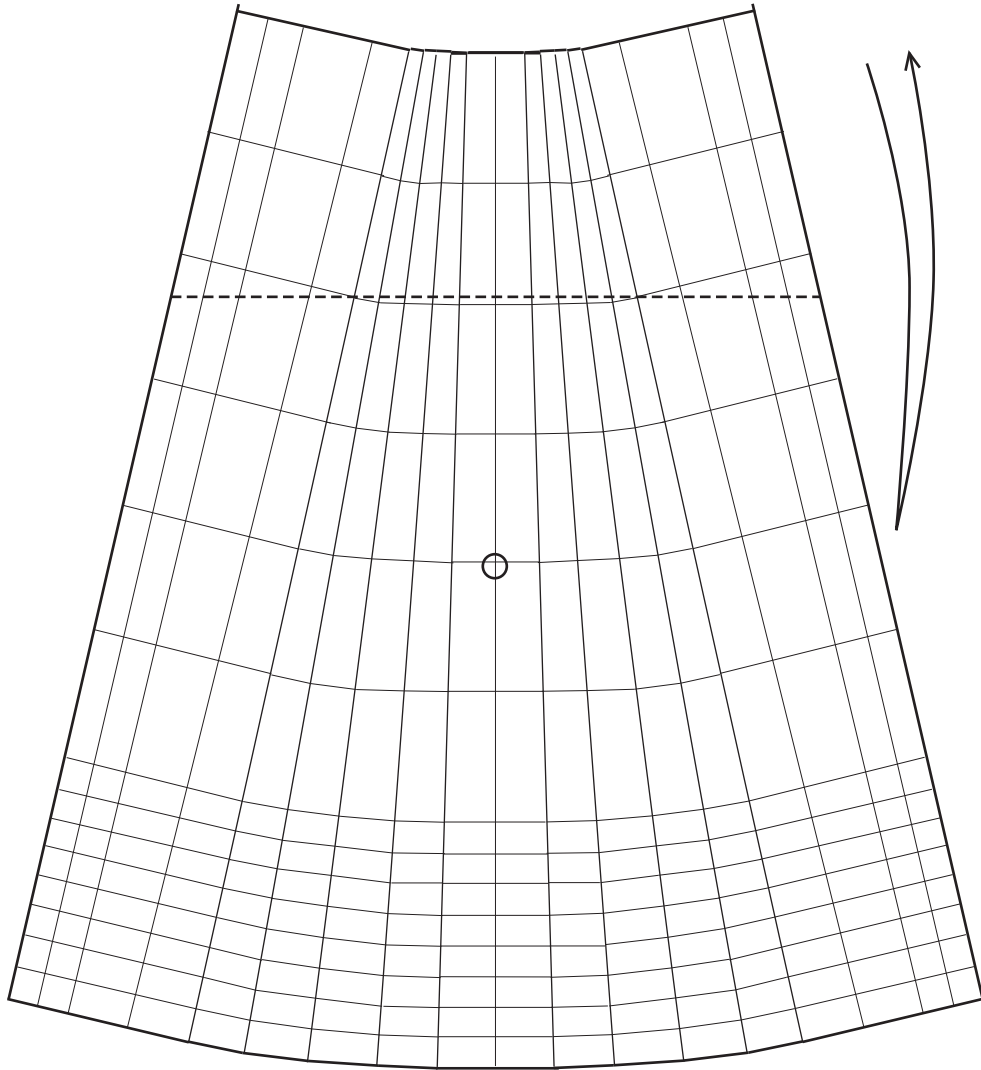

3. Fold and unfold.

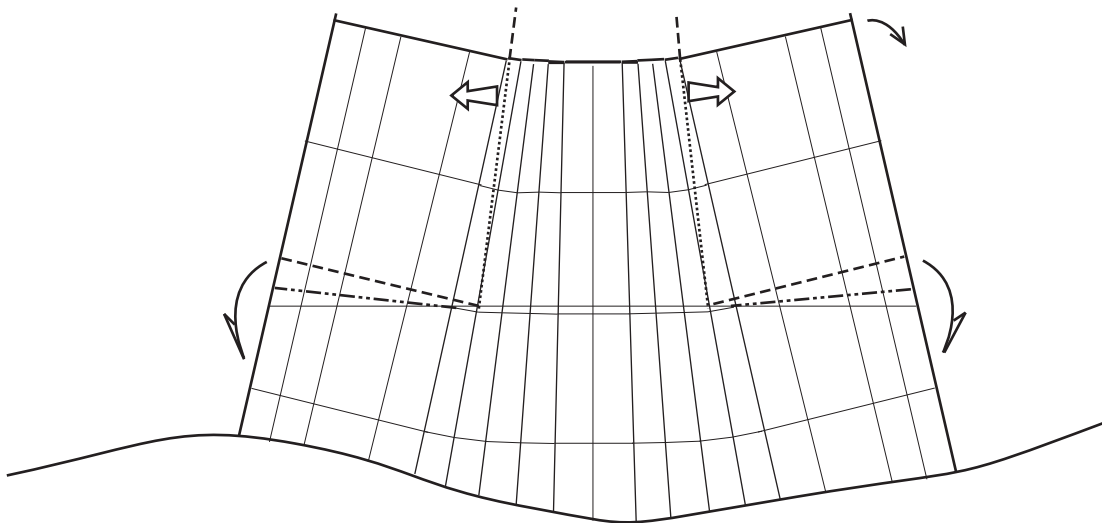

4. Pull out top of outer pleat on either side and fold.

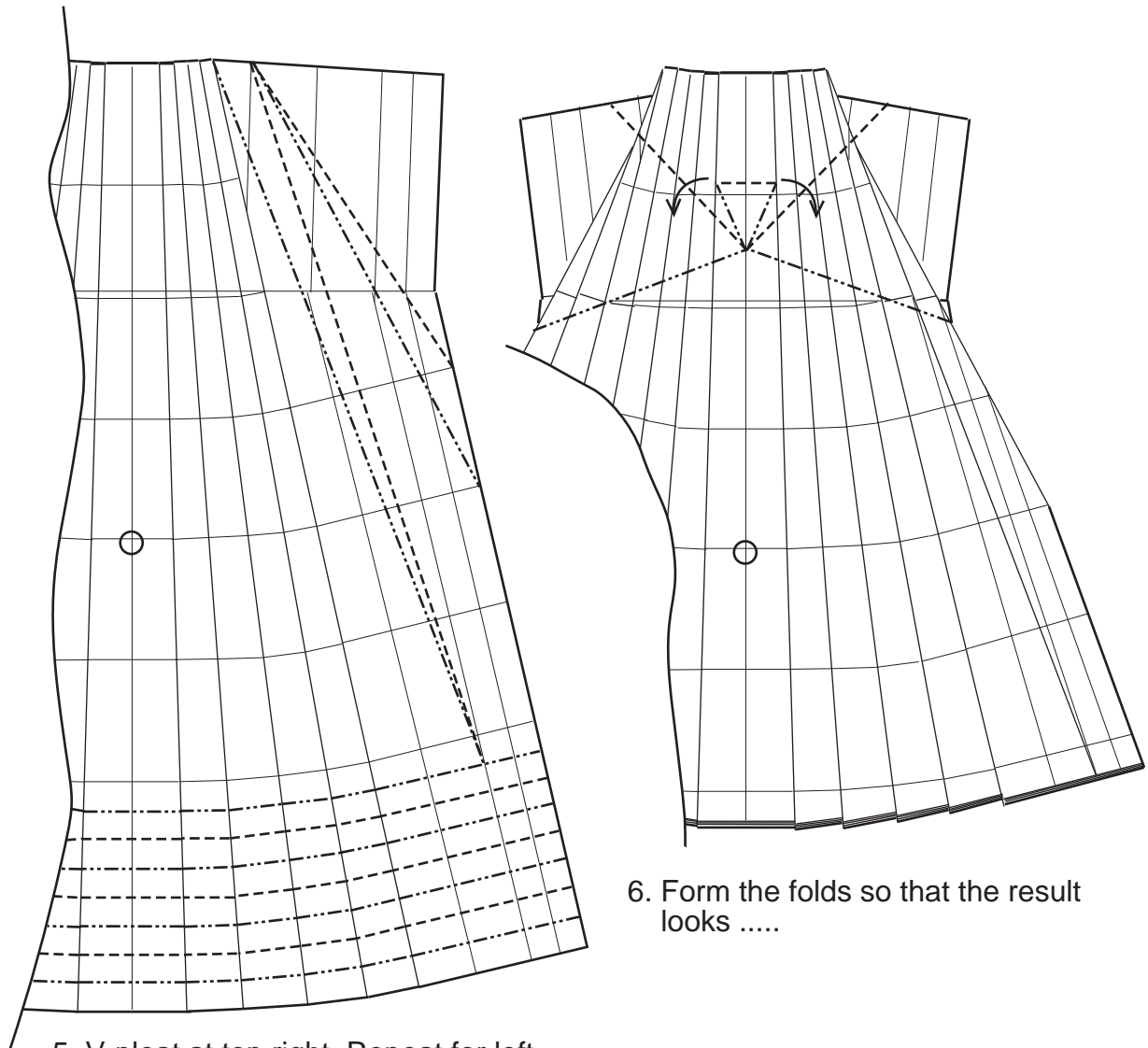

6. Form the folds so that the result looks

5. V-pleat at top right. Repeat for left side. Parallel pleat at bottom. Pull out the V-pleats before doing so, and reform them afterwards over the parallel pleats.

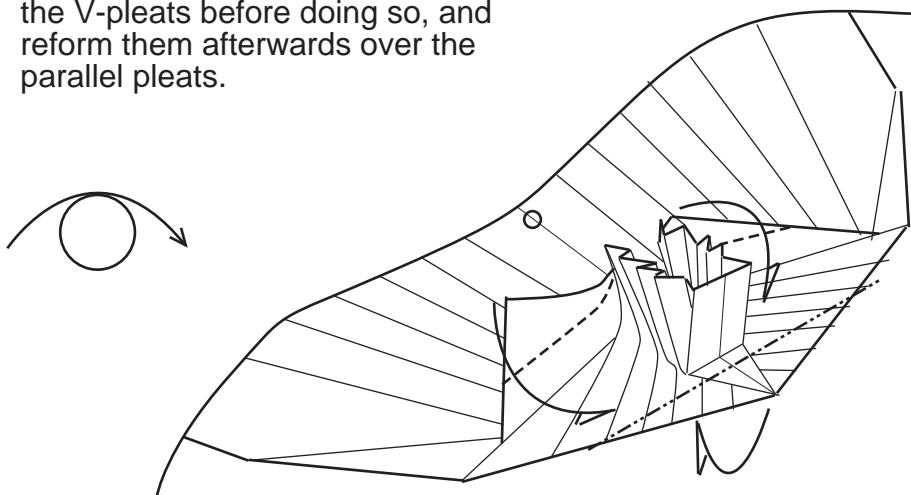

7. like this, as viewed from below. Fold triangle to back and tuck in the two corners of the paper into the pleat folds.

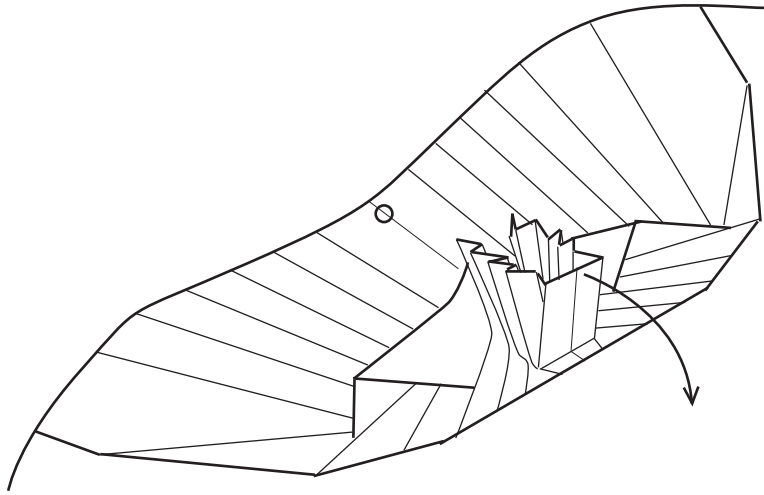

8. Stretch the top edge of paper as far as it can go and flattent the folds.

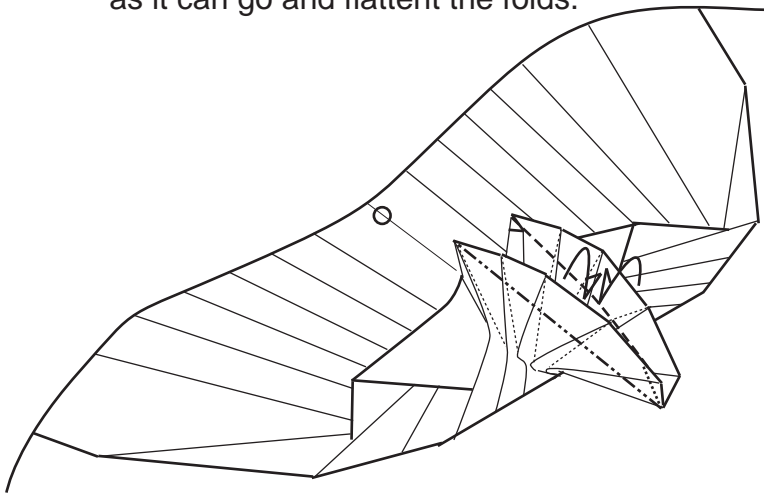

9. Fold in.

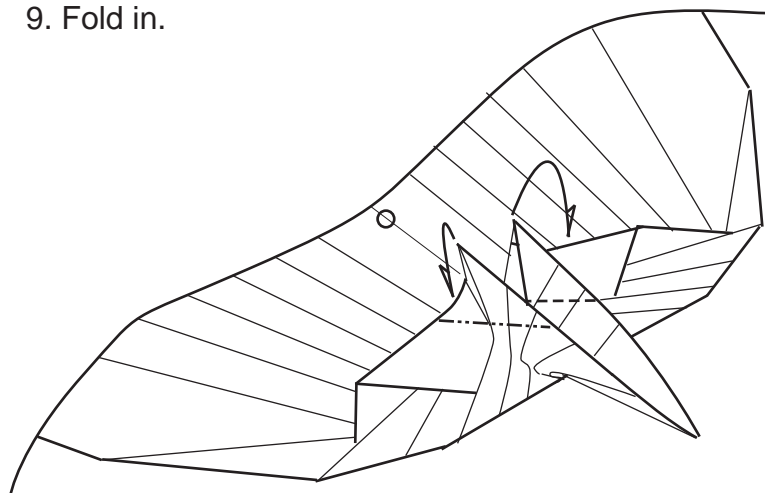

10. Tuck in the two corners.

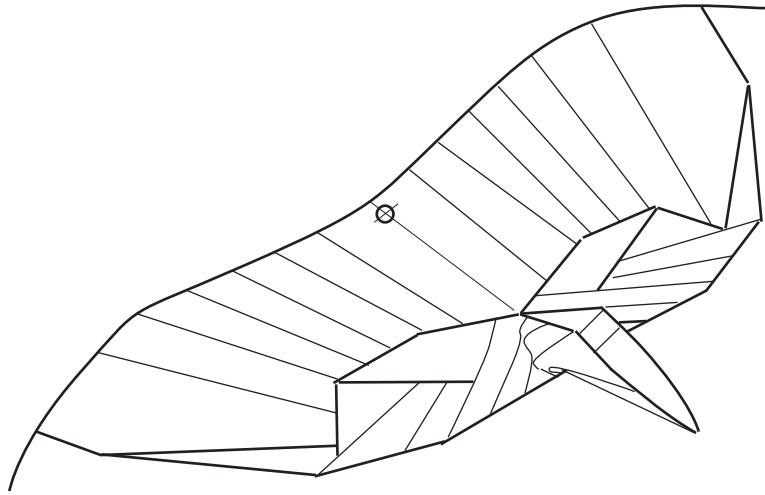

11. ...like this. Turn paper to point head upwards, without turning over paper.

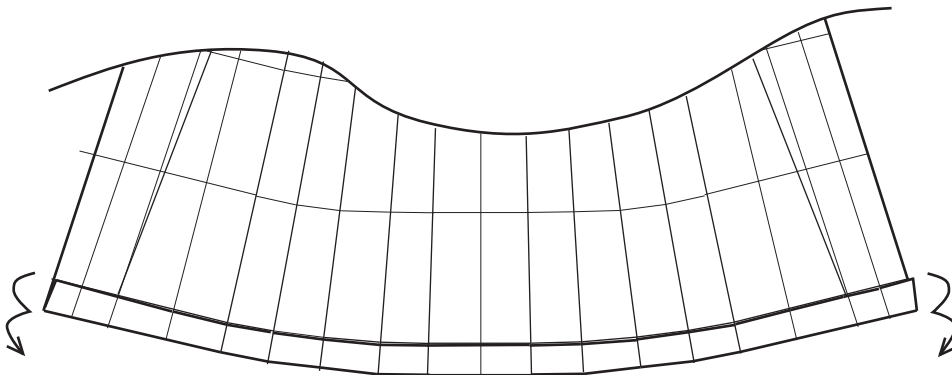

12. Unfold a parallel pleat at bottom layer.

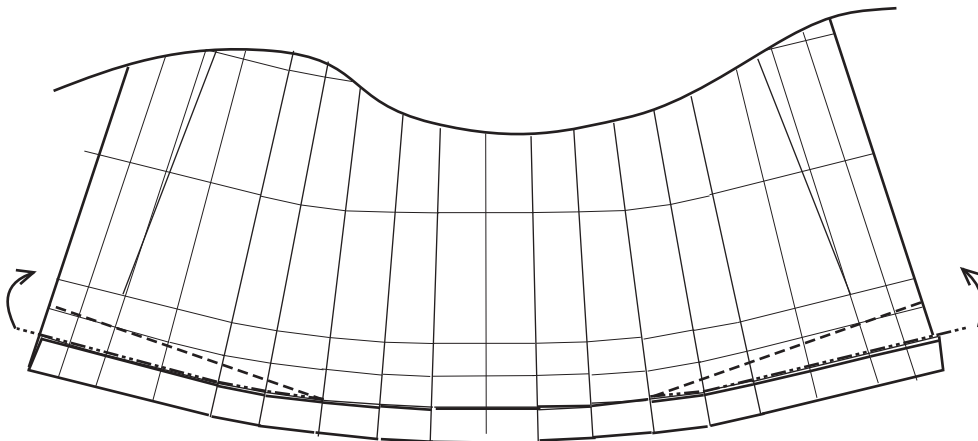

13. Fold. Reform V-pleats formed earlier.

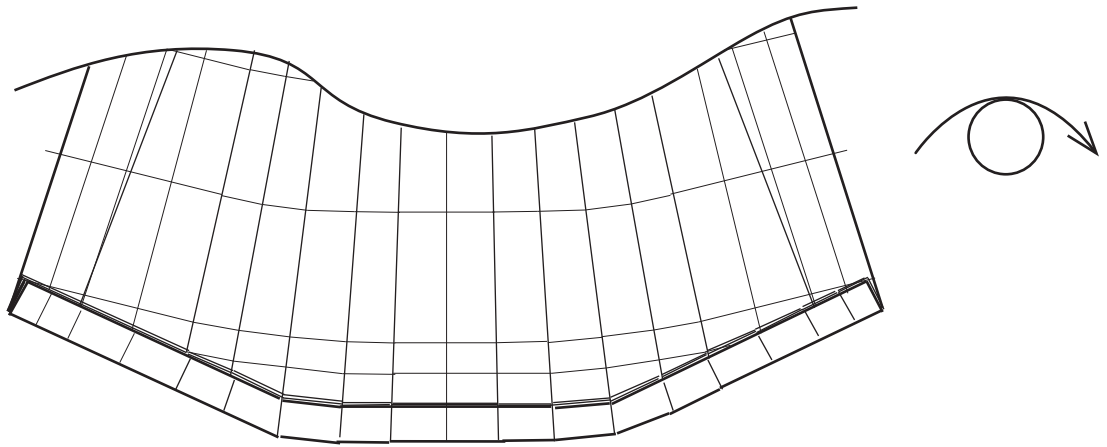

14. Turn over paper. The next few steps shows the folding of the legs and claws.

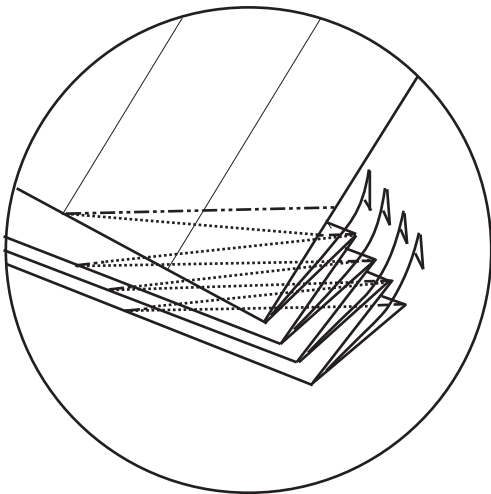

15. Magnified view of bottom right corner for right leg. Reverse fold 4 corners.

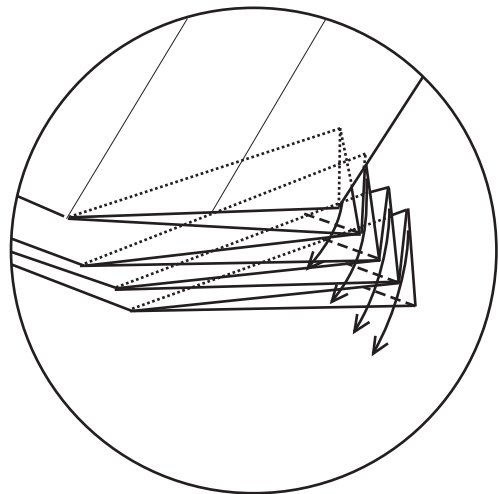

16. Again, reverse fold 4 corners.

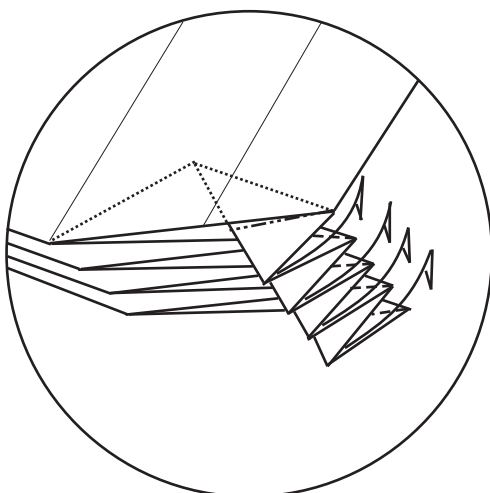

17. Reverse fold 4 corners one more time.

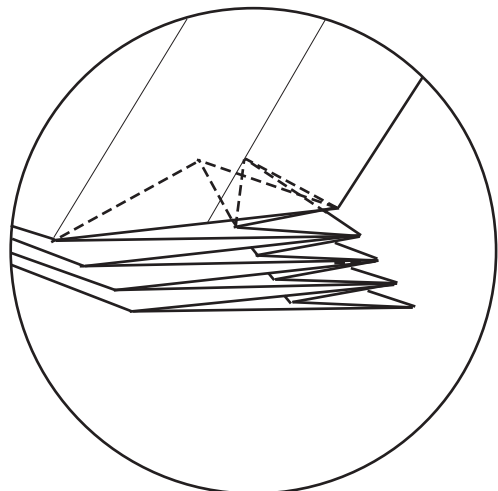

18. Carefully spread out the folds.

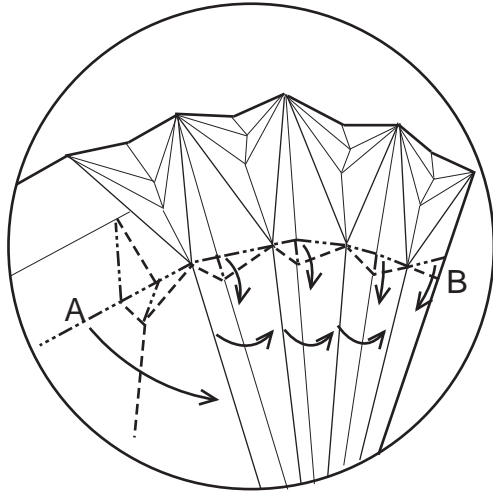

19. View from bottom. Crimp fold at base of eagle's toes. AB should be a straight line along crease line formed earlier on paper. Collapse foot area

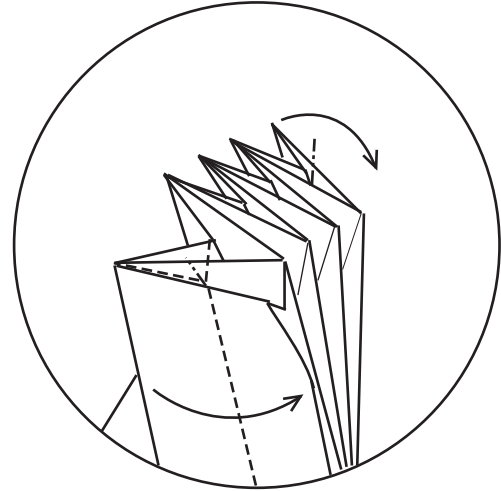

20. ... like this. Fold back point on extreme right to form back claw. Reform fold along left edge of paper. Spread out the three front claws.

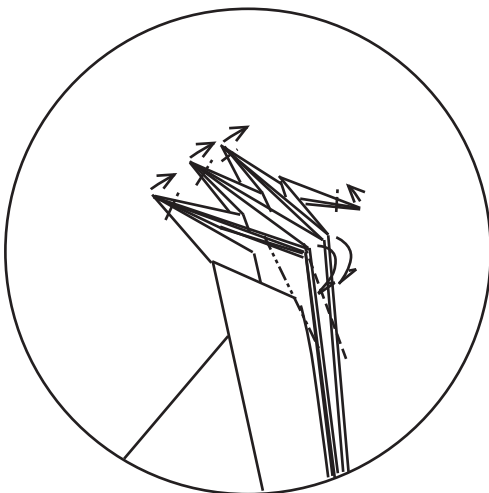

21. Reverse fold the tips to form the talons of the claws. Tuck in the corners, two layers by two layers

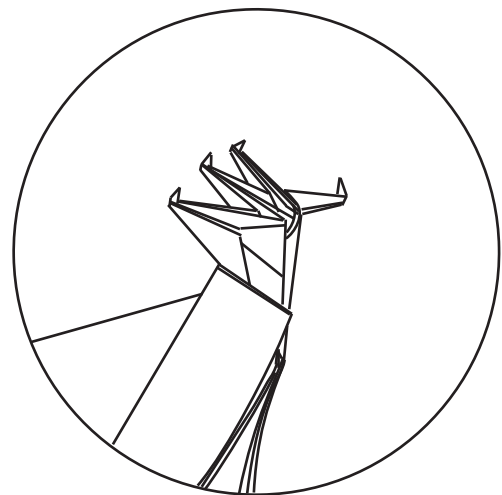

22. Repeat Steps 15 to 21 for left leg. Do not worry that folds do not hold together at this stage. If you are not using foil-backed paper, you can apply wet-folding techniques to bind the folds together later.

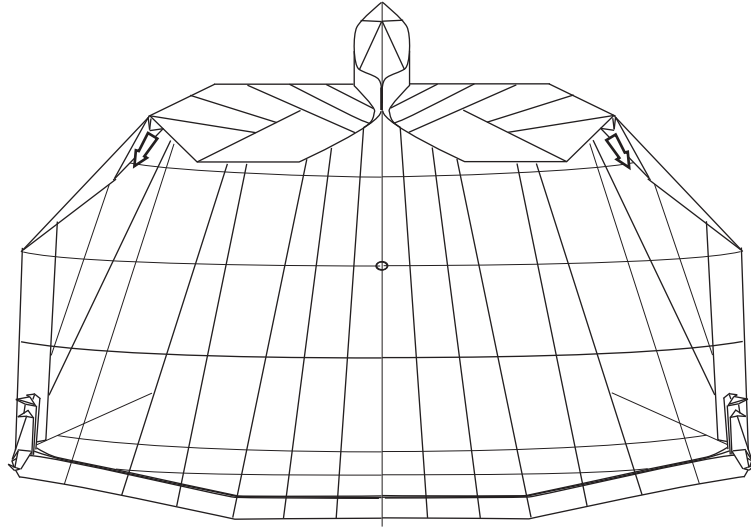

23. View from underside of eagle. Pull out folds and reform.

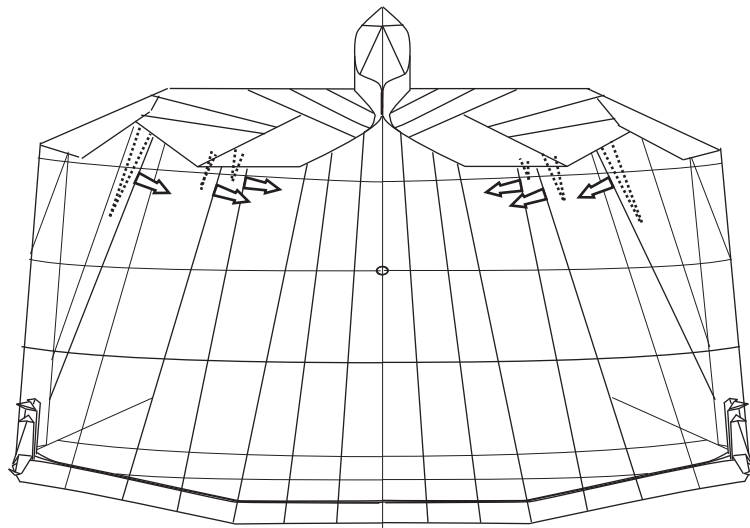

24. View from underside of eagle. There are 6 V-pleat folds on either side. Pull out 3 outer pleats on each side and reform. Note positions of the vertices of reformed V-pleats. The fold lines should reach the top of the wing.

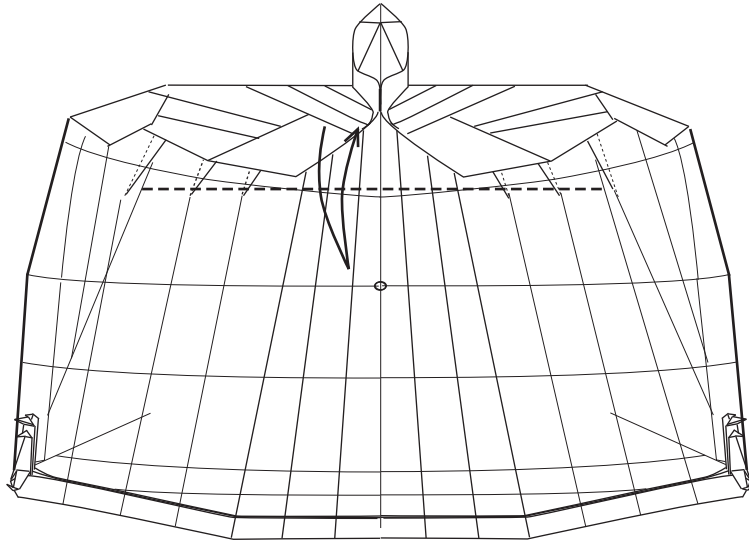

25. Crease such that line lies slightly above the vertices of the V-pleats. Note positions of both ends of the fold line.

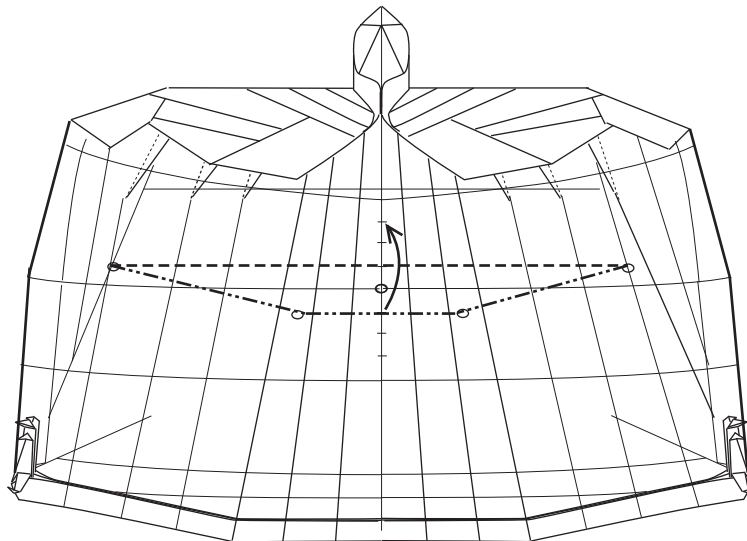

26. Crease valley and mountain folds first before folding. Note carefully where the valley and mountain fold lines are positioned.

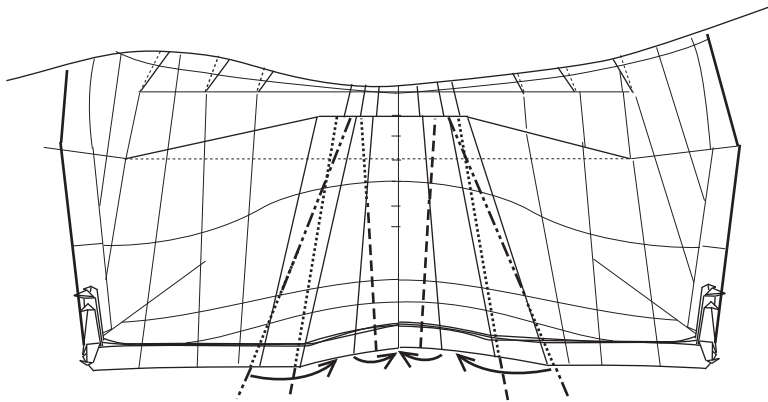

27. Folds do not flatten. Centre of bottom is lifted up. Reform the V-folds to bring this part down...

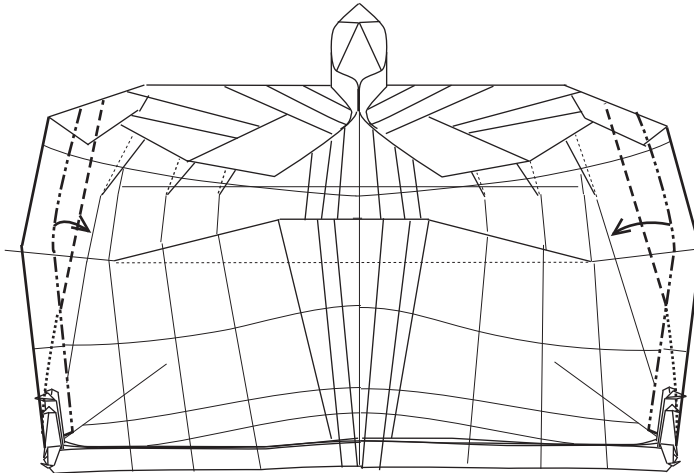

28. ...like this. Reform parallel pleats on both sides.

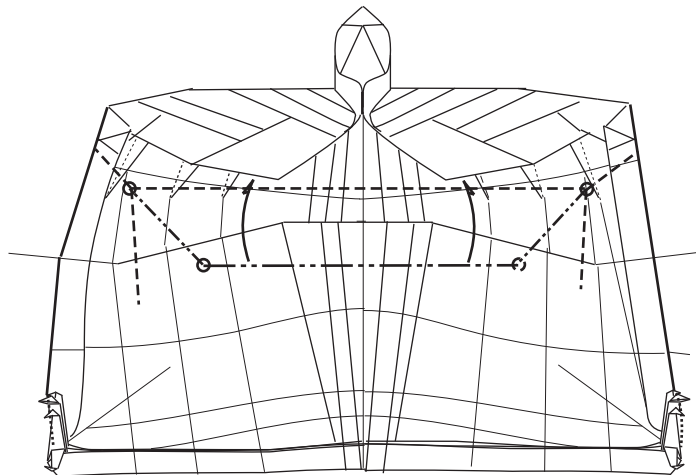

29. Fold and tuck in between the top 2 layers. This is a difficult fold and the folds joining the circled points should be formed first and correctly.

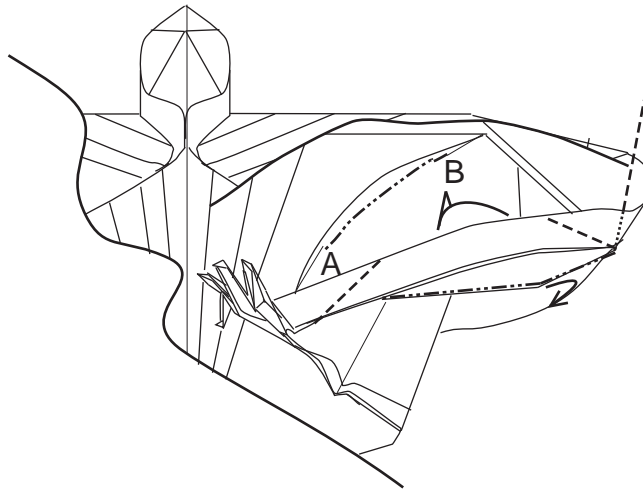

30. Enlarged view. Part of the wing is cut away to show the folds beneath. Flatten folds at and around wing tip and form soft curved fold from A to B. Repeat for right wing.

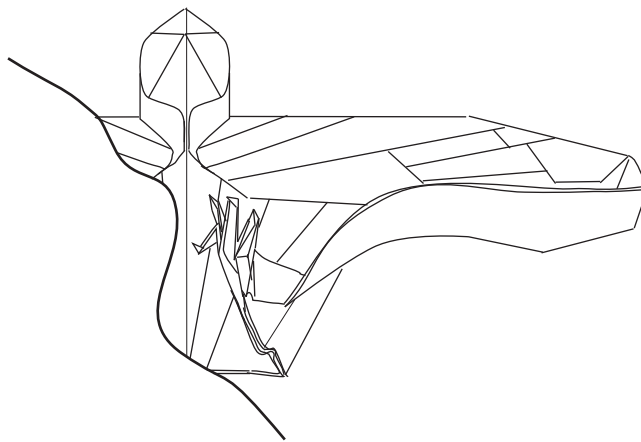

31. Quarter-turn to show inner side of the left leg.

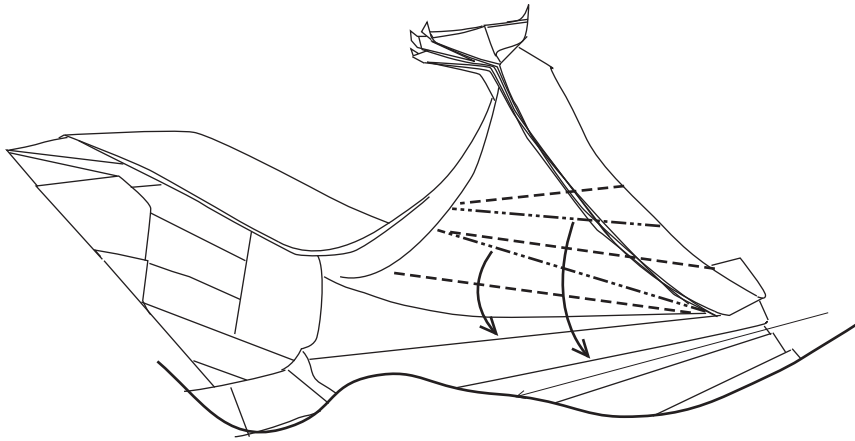

32. Inner side of left leg shown.
 Make series of valley and mountain folds to bring the leg to centre. Repeat for right leg. Much judgement is required to place these folds.

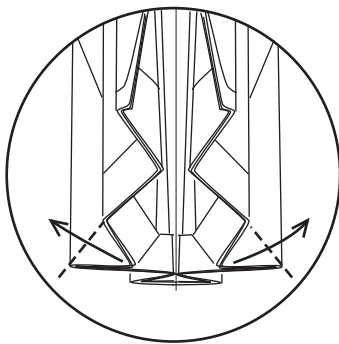

33. View of tail from bottom.
 Reverse fold to spread out the tail...

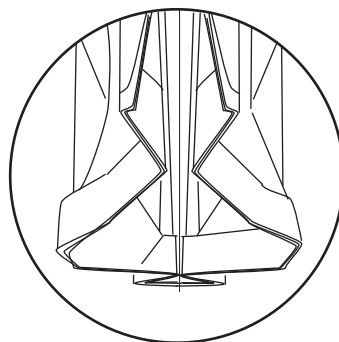

34. ...like this

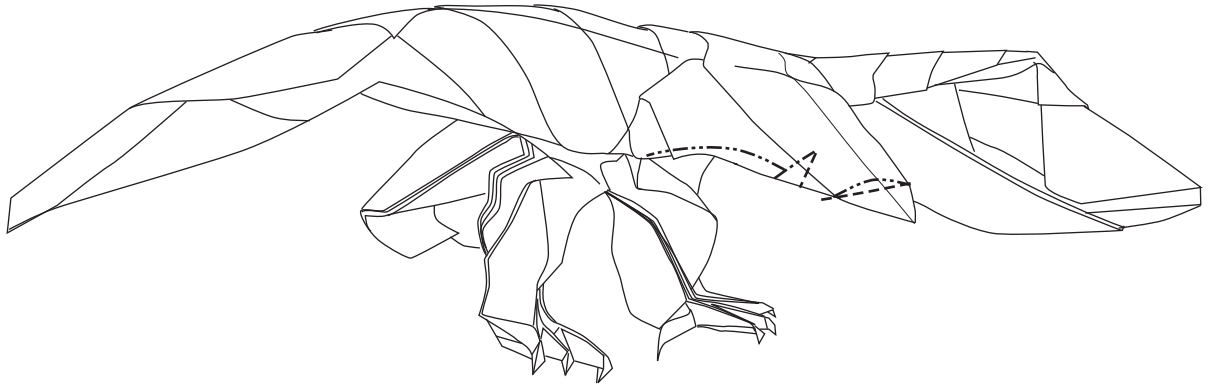

35. Only the head remains unfinished. Make crimp folds for eyes and beak. Bend tip of beak downwards. Narrow neck further.

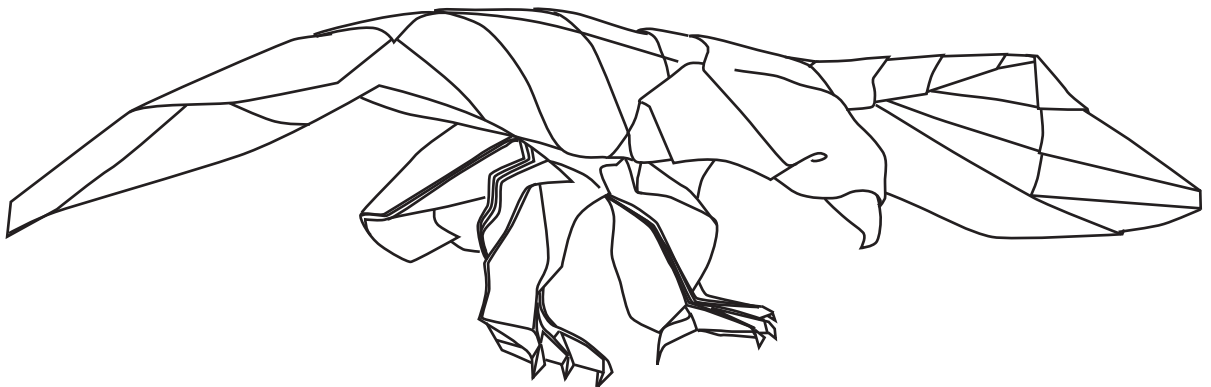

36. THE EAGLE HAS LANDED!